

TR-200 DIRECT ENGINE UNIT TECHNICAL PARAMETERS

1, PRODUCTS PHOTO:



2 UNIT DIMENSIONS&WEIGHT

Condenser size : 780 × 553 × 230 mm Weight: 16kg

Evaporator size : 603 × 538 × 230 mm Weight: 13kg

EVAPORATOR

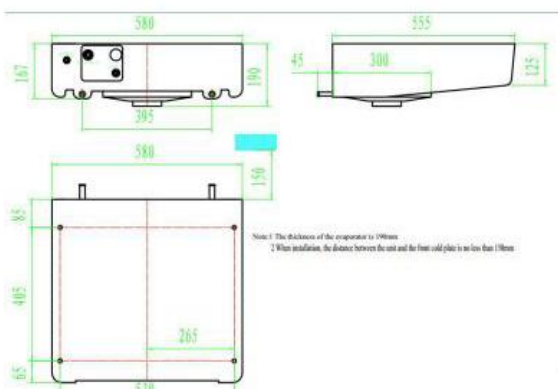

CONDENSER

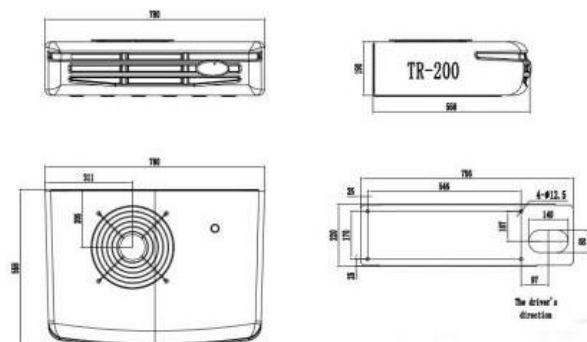

3,DESCRIPTION

Guchen Thermo TR-200 is a new high capacity direct drive refrigeration unit specifically designed for the transportation of fresh or frozen goods in small-sized delivery vehicles with box volumes up to 15m³ (fresh). Super cooling capacity promise the safety of the transporting cargo.

4,STANDARD CONFIGURATION

- ✓ Front Mounted unit and slim evaporator design
- ✓ Compact structure, small size, light weight and fuel savings
- ✓ R-404A Eco-friendly refrigerant
- ✓ In-cab remote display and control
- ✓ Multiple safety protection devices
- ✓ Automatic and manual defrost system

5,SAFETY PROTECT SYSTEM

- ✓ Emergency switch protection
- ✓ Thermal protection guard
- ✓ System high pressure protection
- ✓ System low pressure protection

6,TECHNICAL PARAMETERS

Models		Tr-200		
Cooling Capacity	Road/Standby	Temperature	Watt	Btu
	On the Road	0°C	2200	7550
		-18°C	1127	3840
Airflow Volume		950m ³ /h		
Temp. range		-30°C~30°C		
Refrigerant and volume		R404A&1.0kg		
Defrost		Automatic hot gas defrost		
Voltage		12VDC/24VDC		
Condenser	Type	micro-channel aluminum parallel flow		
	Fan motor	Axial fan		
	Qty of fan motor	1		
	Dimension & weight	780×553×230 mm &16kg		
Evaporator	Type	Copper Tube & Aluminum Fin		
	Fan motor	Axial fan		
	Qty of fan motor	1		
	Dimension & weight	603×538×230 mm &13kg		
Compressor	Model	DY-5H11		
	Displacement	108cc/r		
	No. of cylinder	6		
	weight	6kg		
Electric Standby Options		AC220V/1Ph/50Hz ,AC380V/1Ph/50hZ		
Recommend Box Volume		6~15m ³		

